

Sponsored by: Garrett

**CITY OF MARATHON, FLORIDA
RESOLUTION 2022-16**

A RESOLUTION OF THE CITY COUNCIL OF THE CITY OF MARATHON, FLORIDA, APPROVING THE ATTACHED "FINAL MILE INTERLOCAL AGREEMENT" (ILA) BETWEEN THE CITY OF MARATHON ("MARATHON") AND THE CITY OF KEY WEST ("KEY WEST"), FLORIDA FOR THE INSTALLATION AND MAINTENANCE OF CERTAIN BIKE AND PEDESTRIAN AMENITIES ON MARATHON CITY PROPERTY; PROVIDING FOR AN EFFECTIVE DATE.

WHEREAS, the City of Key West was awarded "Final Mile" FDOT grant funding to increase bike and pedestrian amenities along the US 1 corridor from Marathon to Key West, including five locations in the City of Marathon; and

WHEREAS, the attached "Final Mile Interlocal Agreement" sets forth the respective responsibilities of the cities of Key West and Marathon regarding installation and maintenance of such amenities;

NOW, THEREFORE, BE IT RESOLVED BY THE CITY COUNCIL OF THE CITY OF MARATHON, FLORIDA, THAT:

Section 1. The above recitals are true and correct and incorporated herein.

Section 2. The "Final Mile Interlocal Agreement" between the City of Key West and the City of Marathon, Florida, a copy of which is attached as Exhibit "A," together with such non-material changes as may be acceptable to the City Manager and approved as to form and legality by the City Attorney, is hereby approved. The City Manager is authorized to execute the ILA on behalf of the City.

Section 3. Effective Date. This Resolution shall become effective immediately upon its adoption.

PASSED AND APPROVED BY THE CITY COUNCIL OF THE CITY OF MARATHON, FLORIDA, THIS 8TH DAY OF FEBRUARY, 2022.

THE CITY OF MARATHON, FLORIDA



John Bartus, Mayor

AYES: Cook, Gonzalez, Still, Zieg, Bartus
NOES: None
ABSENT: None
ABSTAIN: None

ATTEST:



Diane Clavier, City Clerk

(City Seal)

**APPROVED AS TO FORM AND LEGALITY FOR THE USE AND RELIANCE OF THE
CITY OF MARATHON, FLORIDA ONLY:**



Steve Williams, City Attorney

EXHIBIT "A"
Final Mile Interlocal Agreement

FINAL MILE
INTERLOCAL AGREEMENT

THIS INTERLOCAL AGREEMENT is entered into as of this 8 day of February 2021, between the City of Marathon, a political subdivision of the State of Florida (hereinafter, MARATHON) and the City of Key West, a municipal corporation organized and existing under the laws of the State of Florida (hereinafter, the CITY).

WITNESSETH:

WHEREAS, City of Key West awarded the “Final Mile” Florida Department of Transportation (FDOT) grant to increase bike and pedestrian amenities along the US1 corridor; and

WHEREAS, in pursuing on this grant, the City of Key West committed its own funds towards site plans and federal permitting processes for these amenities, regardless of their jurisdiction; and

WHEREAS, both the City of Marathon and the City of Key West recognize that these amenities will help alleviate traffic congestion and increase safety along the US1 corridor; and

WHEREAS, the areas listed below are within the jurisdiction of the City of Marathon and

WHEREAS, the City of Marathon is responsible for the maintenance of their own parks, properties and roadway; and

NOW THEREFORE, in consideration of the mutual promises and conditions contained herein, the parties agree as follows:

1. The City of Key West will publicly advertise the project for bidding and enter into a contract with a construction contractor to purchase and install the following Public Area Fixit Stations at the locations designated below within the City of Marathon as shown on the site plants in Attachment “A”, which is attached hereto and made a part hereof:
 - Site 83) Marathon Community Park
 - Site 84) Sombrero Beach Park
 - Site 85) Children’s Rotary Park
 - Site 86) City Hall
 - Site 87) Quay Park
2. The City of Marathon will have the opportunity to review, comment and provide feedback on the selected locations and the amenities.
3. The Work will be performed in accordance with Florida Department of Transportation standards and applicable building codes.

4. The City will submit copies of “as-built” plans to the City of Marathon. The contract for construction will be between the City of Key West and its Contractor; The City of Marathon may monitor the work but is not a party to the contract.
5. The City of Key West will provide to the City of Marathon one (1) extra set of tools per fixit station in case of vandalism.
6. City of Marathon will assume ownership and maintenance responsibility of the fixit stations after acceptance of the improvements by the City and upon issuance of a certificate of final completion of the work to the Contractor.
7. This Agreement shall become effective immediately upon execution and shall continue as long as the amenities remain in place or until termination under other provisions of this Interlocal Agreement.
8. In the event of any failure of compliance by either party hereto with any of its material obligations to the other party as provided for herein such action shall constitute a default under this Agreement.
9. Upon any such default, the non-defaulting party shall provide to the defaulting party a written Notice of such default, which Notice (a “Default Notice”) shall state in reasonable detail the actions the defaulting party must take to cure the same. The defaulting party shall cure any such default, within thirty (30) days following the date of the Default Notice.
10. Notwithstanding the provisions of this Section, if any such default by the defaulting party remains uncured at the conclusion of any specified thirty (30) day cure period, and if the nature of the defaulting party’s obligations are such that more than thirty (30) days is required to effect cure, then the defaulting party shall not be in default hereunder and the non-defaulting party shall not have the right to exercise its termination rights granted herein as a result of any such default, if the defaulting party commences cure within the applicable cure period and thereafter diligently pursues cure to completion of performance.
11. In the event the defaulting party fails to affect any required cure as provided for herein, the defaulting party shall be deemed to be in uncured default hereunder, and the non-defaulting party shall have the right, but shall not be obligated, upon written Notice to the defaulting party, to terminate this Agreement.
12. If such Notice is given, this Agreement shall terminate on the date set forth in the Notice and the parties shall be relieved of all rights and obligations hereunder, except for any rights and obligations that expressly survive termination.
13. MARATHON, as a political sub-division of the State of Florida, as defined in Section 768.28, Florida Statutes, agrees to be fully responsible to the limits set forth in such statute for its own negligent acts or omissions, or intentional tortious acts, which result in claims or suits against either the CITY or MARATHON and agrees to be liable to the statutory limits for any damages proximately caused by said acts or omissions, or intentional tortious acts.

CITY, as a political sub-division of the State of Florida, as defined in Section 768.28, Florida

Statutes, agrees to be fully responsible to the limits set forth in such statute for its own negligent acts or omissions, or intentional tortious acts, which result in claims or suits against either the CITY or MARATHON and agrees to be liable to the statutory limits for any damages proximately caused by said acts or omissions, or intentional tortious acts.

Nothing contained in this Section shall be construed to be a waiver by either party of any protections under sovereign immunity, Section 768.28 Florida Statutes, or any other similar provision of law. Nothing contained herein shall be construed to be a consent by either party to be sued by third parties in any matter arising out of this or any other Agreement.

14. Notices.

All notices, requests, demands, elections, consents, approvals and other communications hereunder must be in writing and addressed as follows, or to any other address which either party may designate to the other party by mail:

If to MARATHON: John Bartus
Mayor
9805 Overseas Highway
Marathon, Florida
33050

With a copy to: Steve Williams
City Attorney
9805 Overseas Highway
Marathon, Florida
33050

If to City: Patti McLaughlin
City Manager
P.O. Box 1409
Key West, Florida
33041

With a copy to: Shawn Smith, Esq.
City Attorney
P.O. Box 1409
Key West, Florida 33041

Any Notice required by this Agreement to be given or made within a specified period of time, or on or before a date certain, shall be deemed to have been duly given if sent by certified mail, return receipt requested, postage and fees prepaid; hand delivered; or sent by overnight delivery service.

15. Attorneys Fees and Waiver of Jury Trial.

In the event of any litigation arising out of this Agreement, the prevailing party shall be entitled to recover its attorneys' fees and costs, including the fees and expenses of any paralegals, law clerks and legal assistants, and including fees and expenses charged for

representation at both the trial and appellate levels.

In the event of any litigation arising out of this Agreement, each party hereby knowingly, irrevocably, voluntarily and intentionally waives its right to trial by jury.

16. Adjudication of Disputes or Disagreements

The City of Key West and the City of Marathon agree that all disputes and disagreements shall be attempted to be resolved by meet and confer sessions between representatives of each of the parties. If the issue or issues are still not resolved to the satisfaction of the parties, then any party shall have the right to seek such relief or remedy as may be provided by this Agreement or by Florida law.

17. Cooperation

In the event any administrative or legal proceeding is instituted against either party relating to the formation, execution, performance, or breach of this Agreement, the City of Key West and the City of Marathon agree to participate, to the extent required by the other party, in all proceedings, hearings, processes, meetings, and other activities related to the substance of this Agreement or provision of the services under this Agreement. The City of Key West and the City of Marathon specifically agree that no party to this Agreement shall be required to enter into any arbitration proceedings related to this Agreement.

18. Governing Law.

This Agreement shall be construed in accordance with and governed by the laws of the State of Florida. Exclusive venue for any litigation arising out of this Agreement shall be in Monroe County, Florida, Lower Keys Division of the Circuit Court or the Southern District of Florida. This Agreement is not subject to arbitration.

19. Entire Agreement/Modification/Amendment.

This writing contains the entire Agreement of the parties and supersedes any prior oral or written representations. No representations were made or relied upon by either party, other than those that are expressly set forth herein.

No agent, employee, or other representative of either party is empowered to modify or amend the terms of this Agreement, unless executed with the same formality as this document.

20. Nonassignability.

This Agreement shall not be assignable by either party unless such assignment is first approved in writing by both parties.

21. Severability.

If any term or provision of this Agreement shall to any extent be held invalid or unenforceable, the remainder of this Agreement shall not be affected thereby, and each remaining term and provision of this Agreement shall be valid and be enforceable to the fullest extent permitted by law.

22. Independent Contractor.

The City of Key West and its employees, volunteers, agents, vendors and subcontractors shall be and remain independent contractor and not agents or employees of the City of Marathon with respect to all of the acts and services performed by and under the terms of this Agreement. This Agreement shall not in any way be construed to create a partnership, association or any other kind of joint undertaking, enterprise, or venture between the parties.

23. Waiver.

The failure of either party to this Agreement to object to or to take affirmative action with respect to any conduct of the other which is in violation of the terms of this Agreement shall not be construed as a waiver of the violation or breach, or of any future violation, breach, or wrongful conduct.

24. Funding.

The parties agree that the City of Key West's responsibility under this Agreement is to provide funding for all initial installation of the bike fixit stations.

25. Survival of Provisions.

Any terms or conditions of either this Agreement that require acts beyond the date of the term of the Agreement, shall survive termination of the Agreement, shall remain in full force and effect unless and until the terms or conditions are completed and shall be fully enforceable by either party.

26. Counterparts.

This Agreement may be executed in several counterparts, each of which shall be deemed an original, all of which taken together shall constitute one and the same instrument.

27. Florida Code of Ethics.

The parties agree that their offices and employees will be required to comply with the standards of conduct for public officers and employees as delineated in Section 112.313, F.S., regarding, but not limited to, solicitation or acceptance of gifts; doing business with one's agency; unauthorized, compensation; misuse of public position, conflicting employment or contractual relationship; and disclosure or use of certain information.

28. Non-Waiver of Immunity.

Notwithstanding the provisions of Section 786.28, F.S., the participation of the City of Key West and the City of Marathon in this Agreement and the acquisition of any commercial liability insurance coverage, self-insurance coverage, or local government liability insurance pool coverage shall not be deemed a waiver of immunity to the extent of liability coverage, nor shall any contract entered into by the City of Key West or the City of Marathon be required to contain any provision for waiver.

29. Privileges and Immunities.

All of the privileges and immunities from liability, exemptions from laws, ordinances, and rules and pensions and relief, disability, workers' compensation, and other benefits which apply to the activity of officers, agent, or employees of any public agents or employees of the City of Key West or the City of Marathon, when performing their respective functions

under this Agreement within the territorial limits of the City of Marathon shall apply to the same degree and extent to the performance of such functions and duties of such officers, agents, volunteers, or employees outside the territorial limits of the City of Marathon.

30. Legal Obligations and Responsibilities.

This Agreement is not intended to, nor shall it be construed as, relieving any participating entity from any obligation or responsibility imposed upon the entity by law except to the extent of actual and timely performance thereof by any participating entity, in which case the performance may be offered in satisfaction of the obligation or responsibility. Further, this Agreement is not intended to, nor shall it be construed as, authorizing the delegation of the constitutional or statutory duties of either party, except to the extent permitted by law.

31. Non-Reliance by Non-Parties.

No person or entity shall be entitled to rely upon the terms, or any of them, of this Agreement to enforce or attempt to enforce any third-party claim or entitlement to or benefit of any service or program contemplated hereunder, and the City of Key West and the City of Marathon agree that neither the City of Key West nor the City of Marathon or any agent, officer, or employee of either shall have the authority to inform, counsel, or otherwise indicate that any particular individual or group of individuals, entity or entities, have entitlements or benefits under this Agreement separate and apart, inferior to, or superior to the community or general or for the purposes contemplated in this Agreement.

[THE REMAINDER OF THIS PAGE INTENTIONALLY LEFT BLANK.]

IN WITNESS WHEREOF, the parties hereto have set their hands and seal the day and year first written above.

CITY OF MARATHON, FLORIDA

BY: 
John Bartus, Mayor

(SEAL)

ATTEST: DIANE CLAVIER, CLERK

BY: 
Clerk

Approved as to form:

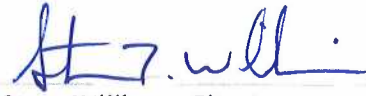
BY: 
Steve Williams, City Attorney

THE CITY OF KEY WEST, FLORIDA

(City Seal)

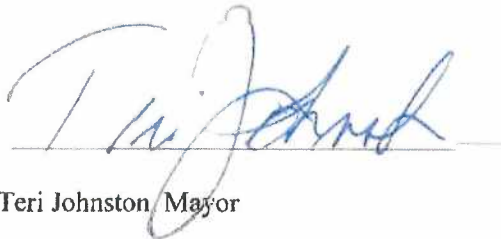
Teri Johnston, Mayor

ATTEST:

Cheri Smith
City Clerk

Approved as to form:

BY: 
CITY ATTORNEY'S
OFFICE

ATTACHMENT 'A'

SITE: 81) OLD 7 MILE BRIDGE
 CATEGORY: FIXIT STATION
 KEY: VACA JURISDICTION: EDOT

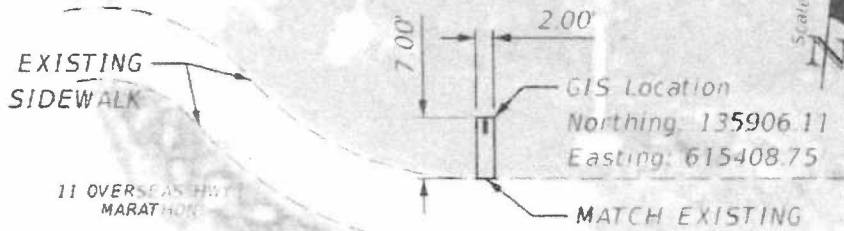

PLANNED AMENITIES
 BICYCLE RACK(S): 0 SR 5 OVERSEAS HWY / US 1
 FIXIT STATION: L MILE MARKER 46.8
 4" CONCRETE (SF): 14.00

SITE: 82) MARATHON GOVT CENTER
 CATEGORY: FIXIT STATION
 KEY: VACA JURISDICTION: MONROE

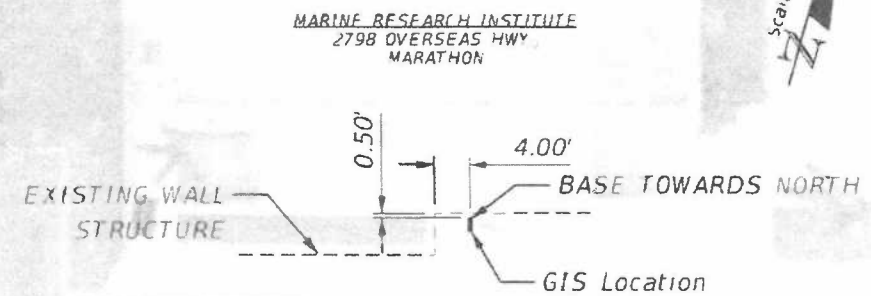

PLANNED AMENITIES
 BICYCLE RACK(S): 0
 FIXIT STATION: L
 4" CONCRETE (SF): 6.00

SITE: 83) MARATHON COMMUNITY PARK
 CATEGORY: FIXIT STATION
 KEY: VACA JURISDICTION: MARATHON

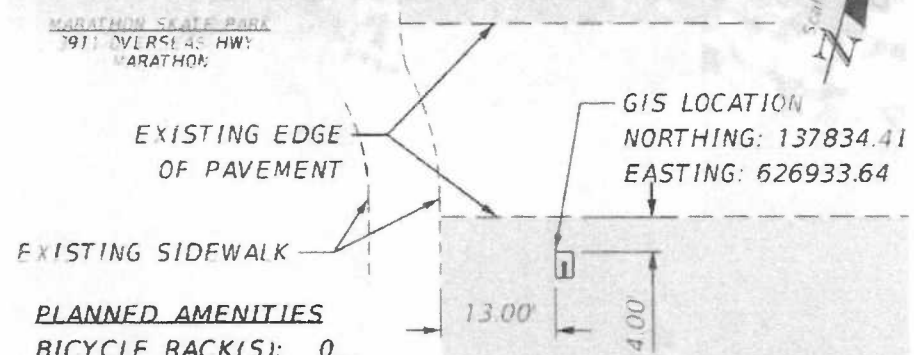

PLANNED AMENITIES
 BICYCLE RACK(S): 0
 FIXIT STATION: L
 4" CONCRETE (SF): 6.00

SITE: 84) SOMBRERO BEACH PARK
 CATEGORY: FIXIT STATION
 KEY: VACA JURISDICTION: MARATHON

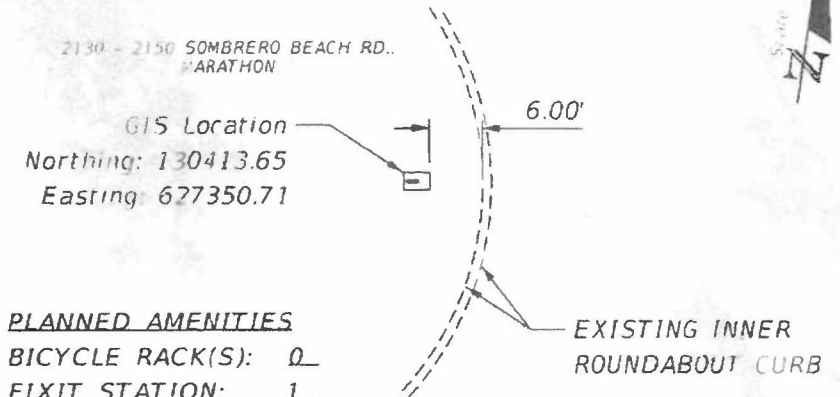

PLANNED AMENITIES
 BICYCLE RACK(S): 0
 FIXIT STATION: L
 4" CONCRETE (SF): 6.00

NOTE: SEE SHEET 50 FOR TYPICAL LAYOUT AND ATTACHMENT INFORMATION.



KCI TECHNOLOGIES, INC. 1425 W CYPRESS CREEK RD., SUITE 101 FORT LAUDERDALE, FLORIDA 33309-2132 (954) 839-6702	CITY OF KEY WEST			PLANS	SHEET NO.
	ROAD NO.	COUNTY	FINANCIAL PROJECT ID		45
	MONROE	446126-1-58-01			

SITE: 85) CHILDREN'S ROTARY PARK
 CATEGORY: FIXIT STATION
 KEY: VACA JURISDICTION: MARATHON

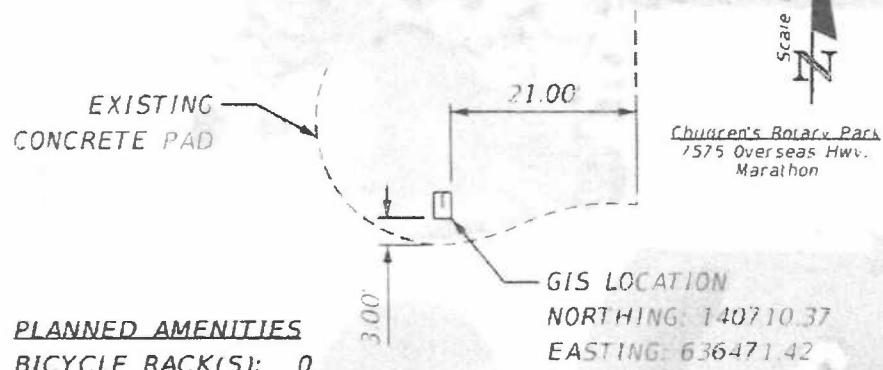

PLANNED AMENITIES
 BICYCLE RACK(S): 0
 FIXIT STATION: L
 4" CONCRETE (SF): 6.00

SITE: 86) OCEANFRONT PARK / CITY HALL
 CATEGORY: FIXIT STATION
 KEY: VACA JURISDICTION: MARATHON

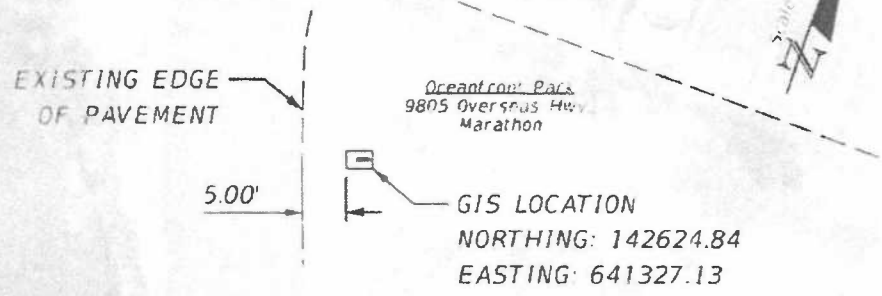

PLANNED AMENITIES
 BICYCLE RACK(S): 0
 FIXIT STATION: L
 4" CONCRETE (SF): 6.00

SITE: 87) QUAY PARK
 CATEGORY: FIXIT STATION
 KEY: VACA JURISDICTION: MARATHON

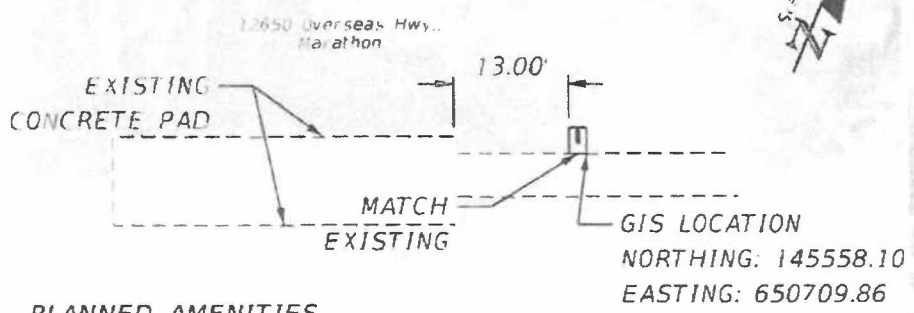

PLANNED AMENITIES
 BICYCLE RACK(S): 0
 FIXIT STATION: L
 4" CONCRETE (SF): 6.00

SITE: 88) MURRAY NELSON GOVT CENTER
 CATEGORY: FIXIT STATION
 KEY: KEY LARGO JURISDICTION: MONROE

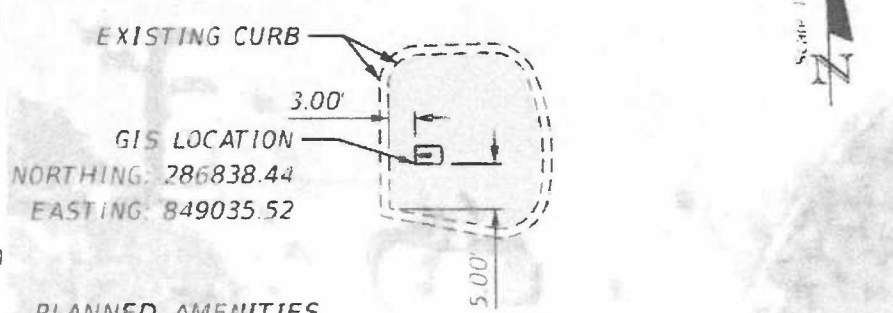

PLANNED AMENITIES
 BICYCLE RACK(S): 0
 FIXIT STATION: L
 4" CONCRETE (SF): 6.00

NOTE: SEE SHEET 50 FOR TYPICAL LAYOUT AND ATTACHMENT INFORMATION



KCI TECHNOLOGIES, INC.

1425 W CYPRESS CREEK RD., SUITE 101
 FORT LAUDERDALE, FLORIDA 33309-2132
 (954) 839-6702

CITY OF KEY WEST

ROAD NO.	COUNTY	FINANCIAL PROJECT ID
	MONROE	446126-1-58-01

PLANS

SHEET NO.

46

RESOLUTION NO. 22-009

A RESOLUTION OF THE CITY COMMISSION OF THE CITY OF KEY WEST, FLORIDA, APPROVING THE ATTACHED "FINAL MILE INTERLOCAL AGREEMENT" (ILA) BETWEEN THE CITY OF KEY WEST ("KEY WEST") AND THE CITY OF MARATHON, FLORIDA ("MARATHON") FOR INSTALLATION AND MAINTENANCE OF CERTAIN BIKE AND PEDESTRIAN AMENITIES ON MARATHON CITY PROPERTY; PROVIDING FOR AN EFFECTIVE DATE

WHEREAS, the City of Key West was awarded "Final Mile" FDOT grant funding to increase bike and pedestrian amenities along the US 1 corridor from Marathon to Key West, including five locations in the City of Marathon; and

WHEREAS, the attached "Final Mile Interlocal Agreement" sets forth the respective responsibilities of the cities of Key West and Marathon regarding installation and maintenance of such amenities; and

NOW, THEREFORE, BE IT RESOLVED BY THE CITY COMMISSION OF THE CITY OF KEY WEST, FLORIDA, AS FOLLOWS:

Section 1: That the attached "Final Mile Interlocal Agreement" between the City of Key West and the City of Marathon, Florida, is hereby approved.

Section 2: That this Resolution shall go into effect immediately upon its passage and adoption and authentication by the signature of the Presiding Officer and the Clerk of the Commission.

Passed and adopted by the City Commission at a meeting held this 4th day of January, 2022.

Authenticated by the Presiding Officer and Clerk of the Commission on 5th day of January, 2022.

Filed with the Clerk on January 5, 2022.

Mayor Teri Johnston	<u>Yes</u>
Vice Mayor Sam Kaufman	<u>Yes</u>
Commissioner Gregory Davila	<u>Yes</u>
Commissioner Mary Lou Hoover	<u>Yes</u>
Commissioner Clayton Lopez	<u>Yes</u>
Commissioner Billy Wardlow	<u>Yes</u>
Commissioner Jimmy Weekley	<u>Yes</u>

TERI JOHNSTON, MAYOR

ATTEST:

CHERYL SMITH, CITY CLERK