

Sponsored by: Garrett

**CITY OF MARATHON, FLORIDA
RESOLUTION 2024-105**

A RESOLUTION OF THE CITY COUNCIL OF THE CITY OF MARATHON, FLORIDA, AWARDED A WORK AUTHORIZATION FOR THE AREA 3 MUDWELL PUMPING SYSTEM UPGRADES TO REYNOLDS CONSTRUCTION, LLC IN AN AMOUNT NOT TO EXCEED \$215,800.22; AUTHORIZING THE CITY MANAGER TO EXECUTE THE CONTRACT AND EXPENDING BUDGETED FUNDS ON BEHALF OF THE CITY; AND PROVIDING FOR AN EFFECTIVE DATE

WHEREAS, the city requires an upgrade to the coatings on the chlorine contact tank at the Area 6 treatment plant, and

WHEREAS, Reynolds Construction, LLC has a continuing services agreement with the city, and,

WHEREAS, staff recommends this contract for approval.

NOW, THEREFORE, BE IT RESOLVED BY THE CITY COUNCIL OF THE CITY OF MARATHON, FLORIDA, THAT:

Section 1. The above recitals are true and correct and incorporated herein.

Section 2. The City Council hereby authorizes the City Manager to enter into an agreement and expend budgeted funds on behalf of the City to Reynolds Construction, LLC in the amount not to exceed \$215,800.22

Section 3. This resolution shall take effect immediately upon its adoption.

PASSED AND APPROVED BY THE CITY COUNCIL OF THE CITY OF MARATHON, FLORIDA, THIS 8th DAY OF OCTOBER 2024.

THE CITY OF MARATHON, FLORIDA



Mayor Robyn Still

AYES: Gonzalez, Matlock, Smith, Landry, Still
NOES: None
ABSENT: None
ABSTAIN: None

ATTEST:



Diane Clayier, City Clerk
(City Seal)

**APPROVED AS TO FORM AND LEGAL SUFFICIENCY FOR THE USE
AND RELIANCE OF THE CITY OF MARATHON, FLORIDA ONLY:**



Steve Williams, City Attorney



City of Marathon
Mr. Dan Saus
Marathon, FL 33040

September 12, 2024

RE: City of Marathon
Replacement of Mudwell Pumps
Service Area 3

Mr. Saus:

Reynolds Construction is appreciative of the opportunity to assemble a proposal for the City of Marathon's Mudwell Pump Removal and Replacement project.

In consideration of the project, based on jobsite reviews, assistance with the project design and coordination with subcontractors to date, Reynolds Construction proposes to complete the scope of work from the City of Marathon and Weiler Engineering Corporation (WEC) dated August 8, 2024 in the amount of:

- 215,800.22 (two hundred fifteen thousand eight hundred dollars and 22 cents)

Please note that Reynolds has amended our service agreement contract with the City of Marathon and has adjusted the materials markup to ten (10) percent; the proposal is inclusive of this amendment.

Please provide direction on how Reynolds shall proceed as time is of consideration for the procurement of the included pump and electrical equipment.

Respectfully Provided:

Reynolds Construction, LLC

A handwritten signature in black ink, appearing to read 'J. Vondersaar', is written over a horizontal line.

Joshua R. Vondersaar



MEMORANDUM

To: Reynolds Construction
From: Steve Suggs P.E.
Date: August 8th, 2024
Re: Area 3 Mudwell Pumps

Project Scope: Replacement of Mudwell Pumps

Objective:

To replace two existing mudwell pumps with drypit submersible pumps by Gordon Hayward, retrofitting them into the existing filter control panel for operation via the current float system. The project will ensure that the new pumps are properly integrated and that all piping and valve requirements are met to maintain system efficiency and compliance with NEC standards.

Scope of Work:

1. **Pump Replacement:**
 - Remove the existing mudwell pumps and replace them with two drypit submersible pumps by Gordon Hayward.
 - The new pumps will be designed to deliver 150 gallons per minute (GPM) at 35 feet of head.
 - Each pump shall have a 3-inch suction and a 3-inch minimum discharge.
2. **Control Panel Retrofit:**
 - Retrofit the existing filter control panel (LCP) to accommodate the new pumps.
 - Install starters within the LCP for the operation of the new pumps.
 - Ensure that the pumps are controlled via the existing float system for on/off operations.
3. **Piping and Valve Installation:**
 - Install all piping using Schedule 80 PVC to ensure durability and corrosion resistance.
 - Install check valves on the downstream side of each pump to prevent backflow and maintain system integrity.
 - Install isolation valves on each side of each pump to allow for easy maintenance and isolation during operations.
4. **Electrical Modifications:**

- Check the existing wire sizes connected to the filter control panel.
- Upsize wires if required to meet NEC (National Electrical Code) loadings and safety standards.
- Perform all necessary electrical connections and modifications to integrate the new pumps into the existing system.

Additional Notes:

- The scope includes ensuring compatibility between the new pumps and the existing control systems, along with the installation of appropriate piping and valves, to maintain operational efficiency and compliance with electrical and mechanical standards.



Reynolds Construction

300 East Broad St
Fairburn, GA 30213

CHANGE PROPOSAL
SUMMARY NO.:

PROJECT NAME	Area 3 - Mudwell Pumps	PROJ. NO.:	
LOCATION:	Marathon, FL	DATE:	09/09/24
OWNER:	City of Marathon	DRAWING NO.:	
ENGINEER:		SPEC. SECTION:	

REFERENCE PCO NO.: 000 FIELD DIRECTIVE NO.: 0 RFI NO.: N/A OTHER:

DESCRIPTION: Area 3 - Mudwell Pumps

This proposal is inclusive of all materials, equipment, & labor for the removal and installation of two (2) submersible drypit pumps and electrical.
Coating to metals shall be only in the direct area of disruption and installation.
Warranty shall be one (1) year from the date of startup and testing of the pumps.
Tax on materials and equipment is adjusted at 10% as part of a single project agreement and amendment to our service contract.
All piping shall be schedule 80 PVC and shall be painted to match the existing piping upon completion.
See attached electrical scope of work and supply. Electrical scope is valid for 30 days. Should a contract not be issued in 30 days, we respectfully reserve the right to modify the quotation.
This proposal includes cost for a rented lull. Please deduct \$1,458 if RC may utilize the owner's lull to set the two pumps & piping.

PRICING INFORMATION

SKILL/TRADE	MAN-HOURS	RATE	COST
1. DIRECT LABOR			
1.A PRODUCT LABOR:	See backup sheet for breakdown	260	\$ 24,263.70
1.B <input type="checkbox"/> FOREMAN <input type="checkbox"/> SUPERINTENDENT	Safety	0	\$ 88.24 \$ -
	QA/QC	0	\$ 86.28 \$ -
1.C OFFICE ENGINEERING:	Superintendent	0	\$ 133.00 \$ -
	Project Engineer	8	\$ 92.75 \$ 742.00
	Project Manager	40	\$ 133.00 \$ 5,320.00
1.D BURDEN	Labor Burden (included in Rates)		\$ -
			\$ 30,325.70

DESCRIPTION	QUANTITY	UNIT	UNIT PRICE	COST
2. MATERIALS AND EQUIPMENT				
2.A INCORPORATED IN WORK:	See Detail Break Down	1	LS \$ 104,254.18	\$ 104,254.18
				\$ -
				\$ -
2.B CONSUMED IN PERFORMANCE:	Small Tools and Expendables (5% of field labor)			\$ 1,213.19
	-(STC pending task)			
2.C EQUIPMENT:	See Backup Sheet	1	LS \$ 2,857.62	\$ 2,857.62
	Fuel and Service 20% of Equip Cost	1	LS \$ 571.52	\$ 571.52
2.D DIRECT COSTS:				\$ 108,896.51
2.E SALES TAX: 7.5%				\$ 8,167.24
				\$ 117,063.75

NAME	DESCRIPTION OF WORK	COST
3. SUBCONTRACTORS		
3.A DIRECT:	See Detail Sheet	\$ 41,550.00
3.B LOWER TIER:		\$ 41,550.00

Contract Time Extension Costs		Days Requested	Daily Rate	COST
Contractor Extension Costs		0	0	\$ -
Subcontractor Extension Costs		0	0	\$ -
*(daily rate is subject to change per actual OH items)				Total Time Extension Costs \$ -
EXTENSION OF CONTRACT TIME:				
N/A	This Proposal does not include any \$ for extension or acceleration but the right to ask for these costs at a later date is expressly reserved if determined to be necessary.			
N/A	Extension cost is included in this proposal			
N/A	Acceleration cost to maintain project schedule are included in this proposal. *			
5. FEE STRUCTURE				
	Rate	COST	Overhead & Profit	SUBTOTAL
A. Contractor				
1. Direct Labor:		\$ 30,325.70	20%	\$ 36,390.84
2. Material & Equipment:	Pumps & Materials @ 10%	\$ 117,063.75	10%	\$ 128,770.12
3. Subcontractors:		\$ 41,550.00	10%	\$ 45,705.00
4. Bond & Insurance:	1.95%	\$ 4,111.89	20%	\$ 4,934.26
TOTAL COST OF THIS CHANGE PROPOSAL (All deductions shown in parentheses):			TOTAL	\$ 215,800.22
RECORD DOCUMENTS: As part of this Change Proposal, the Contractor shall provide applicable record drawing information affected by this change.				
Signed: <u>Josh Vondersaar</u>				
Title: <u>Project Manager</u>			Date: <u>09/09/24</u>	
Contractor: <u>Reynolds Construction, LLC</u>				
ACCEPTANCE BY OWNER				
Signature of Owner's Authorized Representative: _____ Date: _____				
_____ Engineer to prepare necessary change order _____ Engineer to Re-negotiate change proposal as noted above _____ Other as above				
OWNER:	CONTRACTOR: Reynolds Construction		PROJECT	
ENGINEER:	FIELD:		NO.:	
	OTHER:		DATE:	



Nearshore Electric, Inc.

State Certified Electrical Contractor

#EC13001186

Scope of Work

Job #240903

Confidential

Contractor: Reynolds Construction, LLC

Phone: (317) 832-5987 ~ Email: joshua.vondersaar@reynoldscon.com

Project: Area 3 Mud Well Pumps

**Project Address: 4095 Overseas Highway
Marathon, FL 33050**

September 12, 2024

To all concerned,

We are pleased to offer you our proposal for the electrical work required at Area 3 WWTP in Marathon, Florida. All work performed by Nearshore Electric, Inc. shall conform to current codes, regulations, and project specifications. All work performed by Nearshore Electric, Inc. shall be warranted for a period of one year. The following breakdown describes the items and services that Nearshore Electric, Inc. shall provide as well as any exclusion from our scope of work.

INCLUDED IN BID:

- ◆ Provide 2- 10hp Altivar-320 Series VFD's
- ◆ Provide and install stainless steel enclosure to house new VFD's
- ◆ Provide and install ventilation fans for VFD enclosure
- ◆ Provide and install conduit/wire from new VFD enclosure to existing filter control panel
- ◆ Utilize existing filter controls to operate/initiate start stop commands to VFD's using existing floatballs
- ◆ Provide and install 2- VFD speed control pots to control speed of new pumps in existing filter control panel
- ◆ Provide and install new VFD circuit protection (breakers) to match new pump electrical characteristics
- ◆ Workers Comp/General Liability Insurance
- ◆ Taxes
- ◆ Warranty

EXCLUDED FROM BID:

- ◆ Permit fees
- ◆ Davis Bacon Wages/Buy American
- ◆ PLC programming/alterations/repairs
- ◆ SCADA programming/alterations
- ◆ Pumps/motors
- ◆ Floatballs (use existing)
- ◆ Any Scope of work not clearly shown on drawings or within the bid documents and/or specifications is not included in this proposal.

We propose to furnish material and labor, complete in accordance with the above specifications, for the lump sum of: **Forty-One Thousand Five Hundred Fifty Dollars and No Cents \$41,550.00**

Authorized Signature _____

Jeffrey L Kirk - President

Date 9/12/2024

Joshua Vondersaar

From: nearshore@bellsouth.net
Sent: Monday, September 9, 2024 8:14 AM
To: Joshua Vondersaar; Jason Brownlee
Subject: RE: Quote - Pump Electrical / VFD's

WARNING: This email originated outside of Reynolds Construction from nearshore@bellsouth.net. DO NOT CLICK LINKS OR ATTACHMENTS UNLESS YOU RECOGNIZE THE SENDER AND KNOW THE CONTENT IS SAFE.

I met on site with Steve on Friday. The following items need to be addressed and included in the SOW. I will start working up pricing on the assumption that the below items will be required and be part of the SOW.

1. Provide 2- 10HP VFDs
2. Provide a NEMA 3R stainless steel enclosure for the VFD's
3. Provide a means of controlling the VFD speed at the new VFD enclosure
4. Install air circulating fans in VFD enclosure
5. The VFD's start and stop commands will be controlled by the existing floatballs
6. Provide an alternator to alternate the pumps in auto.
7. Provide a HOA switch to operate the VFD's in hand and auto. Auto will be controlled by the existing floats.
8. New mud well pumps will not be required to be interfaced with the existing SCADA system
9. Use the existing power at the filter control panel to power new VFD's and controls

Let me know if I need to include anything else.

Thanks

Jeffrey L. Kirk
President

Nearshore Electric, Inc.

5680 1st Avenue, Suite 5
Key West, FL 33040
Ph: (305) 294-3991 Fx: (305) 294-3043

Visit us at: WWW.NearshoreElectric.com

From: Joshua Vondersaar <joshua.vondersaar@reynoldscon.com>
Sent: Sunday, September 8, 2024 9:27 PM
To: Jason Brownlee <Jason.Brownlee@reynoldscon.com>; nearshore@bellsouth.net
Subject: Quote - Pump Electrical / VFD's

How is this pricing coming along?

What is realistic for us to get a quote together? I am not pushing, just wanting to understand.



EBARA
HAYWARD GORDON

EBARA HG ULC
5 Brigden Gate
Halton Hills, ON L7G 0A3
P: (905) 693-8595
www.ebarahg.com

QUOTATION FOR EBARA HG ULC SOLIDS HANDLING PUMPS

Date:	9/5/2024	Project Reference:	Marathon WWTP
Quotation No.:	Q4-82694-D9W8 Rev. 1	Equipment Reference:	

Customer:	Moss Kelley Inc. 7284 West Palmetto Park Road Suite 304 Boca Raton FL 33433	Delivery:	20-22 weeks after approval
		Incoterms:	EXW
		Freight:	PREPAID
		Terms of Payment:	0 {Net 30 Days}
		Taxes:	Not Included
		Price Validity	60 days
		Currency:	US \$
Attention:	W. Ben McDorman	Salesperson:	David Caton
		Submitted By:	Jamilee McGraw

PRODUCT:

QTY	MODEL	UNIT SELL PRICE	LOT SELL PRICE
2	HAYWARD GORDON XR3(11)-I TORUS RECESSED IMPELLER PUMP	\$46,770.00	\$93,540.00

CONSTRUCTION DETAILS:

Wet End:	ASTM A532 Super Ni-Hard (650BHN) Casing, Impeller and Wearplate
Seal:	Tandem Seal (TC Lower)
Ports/Flanges:	4" suction x 3" discharge - 125#RF
Motor Details:	7.5HP, 1200RPM, 460V/3/60, TENV-XP w/50ft power cable
Drive:	Close Coupled
Guard:	N/A
Base/Coverplate:	Cast Iron Elbow w/Non Sparking Quick Disconnect Flange
Pump Setting:	Immersible

APPLICATION DETAILS:

Fluid:	Mud and grit	Impeller Diameter:	9.8"	Solids:	
Capacity:	150 GPM	Viscosity:	Waterlike	NPSHR:	Flooded
Head:	35 ft	Temperature:	Ambient		
Pump RPM:	1150 RPM	Specific Gravity:	1.00		

REMARKS:

--

GENERAL COMMENTS:

- Price validity is based on receipt of complete approval and release for production no more than eight weeks after drawings have been submitted by EBARA HG ULC.
- EBARA HG ULC's standard Terms and Conditions of Sale apply and are an integral part of this quotation unless specifically noted otherwise in this proposal.
- All start-up and instructional services not included unless specifically noted otherwise in this proposal.
- All starters and control equipment are not within EBARA HG ULC's scope of supply and are to be supplied by others unless specifically noted otherwise in this proposal.
- This proposal does not include installation, wiring, field painting or any other items except as specifically described above.

Ebara HG ULC
5 Brigden Gate · Halton Hills · ON · CANADA · L7G 0A3
T: 905-693-8595
<https://www.ebarahg.com>

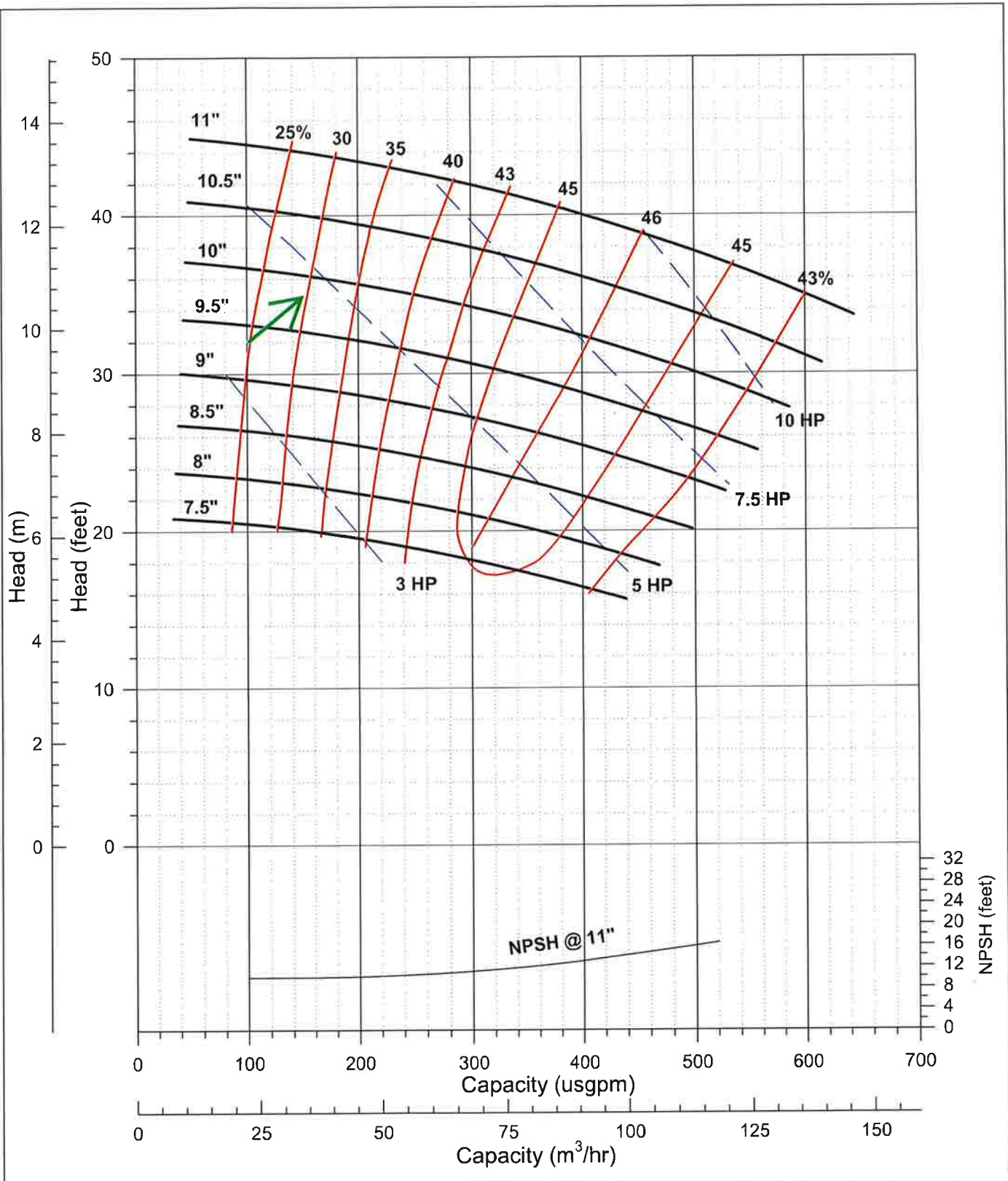

HAYWARD GORDON ULC.  Performance Curves TORUS Pumps	MODEL XR3(11)	SIZE 3 x 4 x 11	CURVE 005-10740	REV. 0
	DRN.DATE July 26/17	DRN. RP 4"	MAX SPHERE 1150 RPM	IMP.DIA. VARIABLE

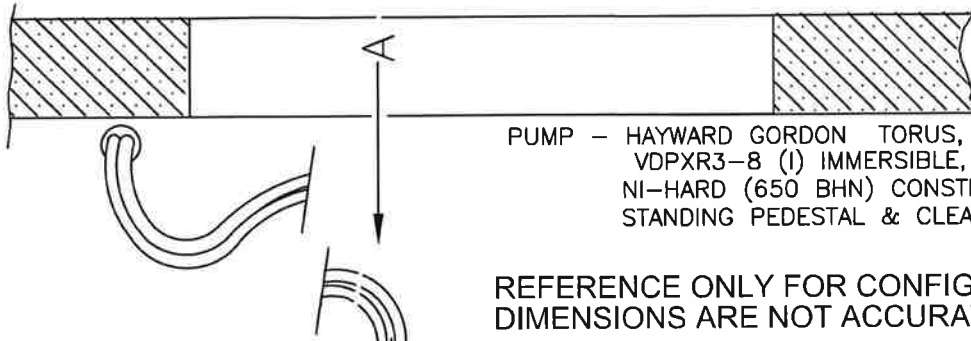

PUMP - HAYWARD GORDON TORUS, MODEL VDPXR3-8 (1) IMMERSIBLE, IN SUPER NI-HARD (650 BHN) CONSTR. C/W FREE STANDING PEDESTAL & CLEAN-OUT ELBOW.

REFERENCE ONLY FOR CONFIGURATION. DIMENSIONS ARE NOT ACCURATE

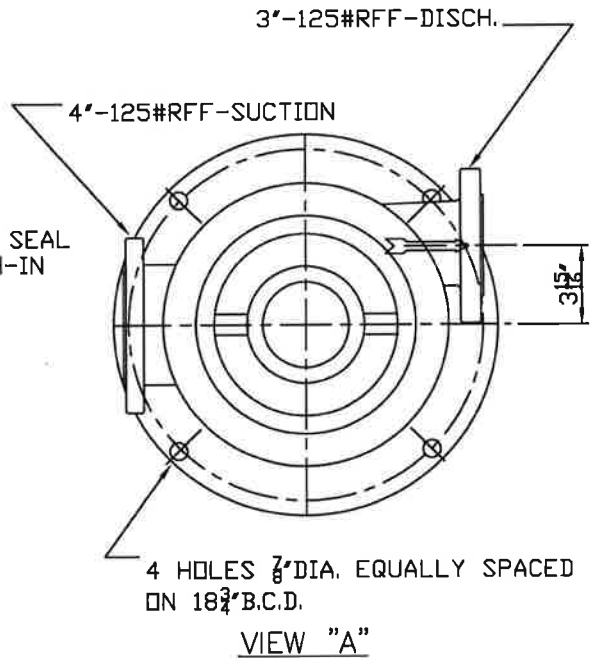
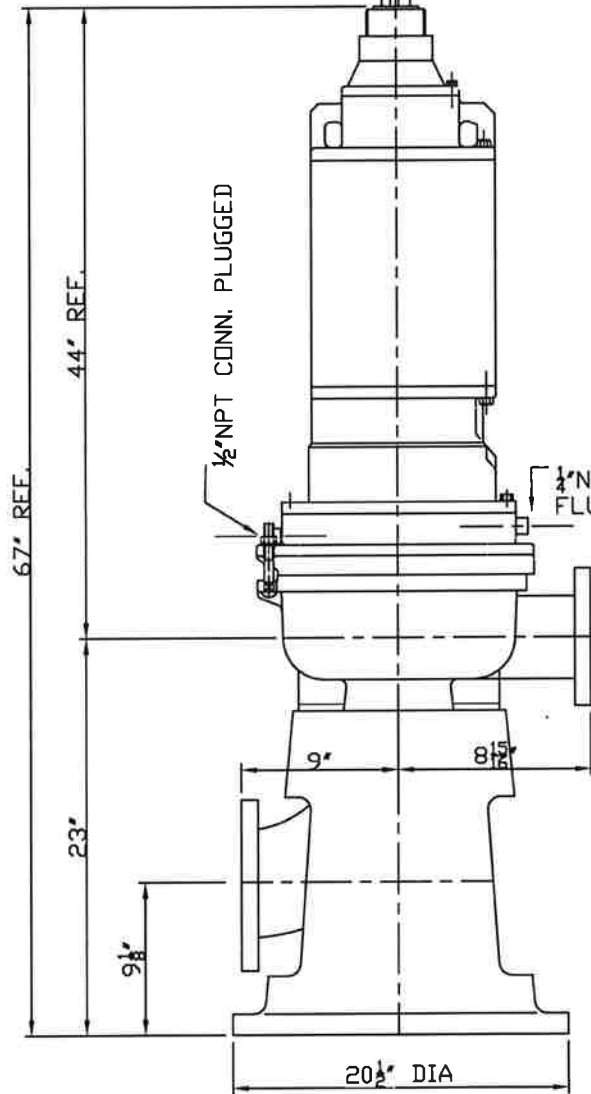

CAPACITY:
 HEAD:
 SPEED:
 LIQUID:
 TAG:
 QTY.:

3			
2			
1			
NO.	DATE	BY	REVISION
HAYWARD GORDON LTD. TORONTO MONTREAL CALGARY VANCOUVER			
SCALE	CUST. P.O. NO.	GEN. ARRANGEMENT DWG.	
NONE [J]	12214		
DATE	H.G. JOB NO.		
DRN.	DWG. NO.		

UNLESS CERTIFIED ALL CONSTRUCTION AND DIMENSIONAL DATA ARE FOR GENERAL INFORMATION ONLY AND ARE SUBJECT TO CHANGE WITHOUT NOTICE.



EBARA
HAYWARD GORDON

EBARA HG ULC
5 Brigden Gate
Halton Hills, ON L7G 0A3
P: (905) 693-8595
www.ebarahg.com

TERMS AND CONDITIONS OF SALE

FORMATION OF AGREEMENT

These Terms and Conditions of Sale apply to the purchase of Products, Services, or both, by Buyer from EBARA HG ULC. (hereinafter referred to as "Seller"), each as identified in Seller's quote. These Terms and Conditions, together with Seller's quote, comprise the entire agreement between the parties (the "Agreement").

Seller's agreement to furnish Product or Services is expressly conditioned on Buyer's agreement to these Terms and Conditions. An order for Products, Services, or both, constitutes Buyer's acceptance of these terms and conditions. Seller rejects any terms, conditions, or warranties in Buyer's purchase order or other document or communication that are additional to or differ from those set out in this Agreement, unless set out in writing and signed by Seller's authorized representative.

PRICES

Quotes. Prices in Seller's quote are valid for 30 days from the date of the quote unless otherwise specified in writing.

Currency. Prices are in the currency specified in Seller's quote. If no currency is specified, prices to buyers located in Canada are in Canadian dollars and prices to all other buyers are in US dollars.

Taxes excluded. Prices do not include any Taxes related to the Products or Services supplied under this Agreement, which are the responsibility of Buyer, unless Buyer presents a waiver or an exemption certificate acceptable to Seller.

PAYMENT

Terms. Buyer will pay all invoiced amounts in full, without deduction, back charge or set-off, payment is not contingent on Buyer receiving payment from Buyer's customer. All invoices are payable within 30 days from the date of Seller's invoice, unless agreed to by Seller's authorized representative. All claims against invoices must be made within 30 days after receipt of goods.

Payment Method. Seller reserves the right to review Buyer's credit and extend or deny credit. The Buyer consents to provision of credit information and to the disclosure of information concerning the Buyer to credit agencies or financial institutions. Upon determination that the Buyer's creditworthiness has changed adversely, or does not satisfy current credit standards, Seller may change the credit limit. Buyer is hereby notified that payments by credit card will incur a 2% fee. NSF cheques will be subject to a \$100 charge.

Late Payment. If payment is not made when required, Seller may at its option take one or more of the following actions: (i) treat such failure as a repudiation of all or a portion of the order that has not been fully performed and immediately suspend performance, (ii) continue production and make shipment under reservation of title or a security interest, and demand payment against tender of documents of title; (iii) charge interest at the lesser of 2% per month with an annual cap of 24% and the maximum rate permitted under applicable law, from the due date until paid, plus Seller's reasonable costs of collection; (iv) enter the premises where any Products for which Buyer has not paid are located, repossess such Products whatever the mode of their attachment to realty or other property, sell the repossessed Products, apply the proceeds to the overdue payment, and recover any deficiency from Buyer; (v) cancel credit privileges without notice; (vi) accelerate payment of the full balance owed; (vii) recover from the Buyer all costs incurred in collecting any unpaid amounts, including, but not limited to, collection suit fees, legal fees, and court costs.

DELIVERY, RISK, TITLE

Delivery dates. Delivery dates stated in advance of shipment, including in Seller's quote, are estimates only and are not guaranteed. Seller will not be liable for or penalized because of delays in shipment for any cause. Seller reserves the right, upon prior notice to Buyer, to make partial deliveries or partial performance, which may be separately invoiced.

Buyer Delay. If Products cannot be shipped to or received by Buyer when ready because of any cause attributable to Buyer or its other contractors, Seller may store the Products at the sole expense and risk of Buyer; in such case, Seller will invoice Buyer and terms of payment will apply as if delivery had been made on the original delivery date.

Damage/Shortage. Claims for damages or shortages must be made within 5 days after receipt of Products.

CHANGES

Orders accepted by Seller are not subject to change or cancellation by Buyer, except with Seller's written consent. Where Seller authorizes changes (including changes to specifications, and special packaging, tests, or inspections in addition to Seller's normal procedures and not set out in Seller's Quote), Seller may charge Buyer reasonable costs of such change.

Seller will make every effort to maintain initial prices throughout the drawing and submittals process. For the avoidance of doubt, in the instance of any change and resubmittal Seller reserves the right to adjust the price in accordance with equity and necessity.

Further, should the Buyer not respond to confirm drawings and submittals in 30 days, the initial price quoted may no longer be valid and may be subject to change in accordance with equity and necessity.

Ebara HG ULC
5 Brigden Gate · Halton Hills · ON · CANADA · L7G 0A3
T: 905-693-8595
<https://www.ebarahg.com>



EBARA
HAYWARD GORDON

EBARA HG ULC
5 Brigden Gate
Halton Hills, ON L7G 0A3
P (905) 693-8595
www.ebarahg.com

RETURNS

Goods may not be returned without prior authorization of seller and will incur a minimum 20% restocking fee. Returns are at Seller's sole discretion. Returns of custom products will not be accepted.

INSTALLATION

All Products will be installed by and at the risk and expense of Buyer, unless otherwise specified in Seller's quote or agreed to in writing.

WARRANTY

Seller warrants that during the warranty period:

- (i) all Products sold by it to Buyer pursuant to the Agreement, when properly stored, installed, used and maintained by Buyer, will in all material respects, conform to the specifications and be free from defects in materials and workmanship under normal usage; and
- (ii) the Services performed by Seller will be performed in a good and workmanlike manner in accordance with any mutually agreed specifications.

Warranty Period. The warranty period for Products is one year from date of shipment.

Warranty Claims/Seller's Obligations. A claim must be submitted in writing, within 30 days of discovery, within the warranty period, to give rise to Seller's obligations. Seller's sole liability and Buyer's exclusive remedy for a breach of this warranty is limited to repair or replacement by Seller, in the case of the Product warranty, and re-performance by Seller in the case of the Services warranty. Such repair, replacement or reperformance will not extend the warranty period. Seller may require access to complete and accurate records of operation and maintenance during the warranty period, or the return of defective parts, freight prepaid, before a warranty claim is recognized.

Third-party components.

Products may contain components from third party manufacturers. Seller will use reasonable commercial efforts to extend to Buyer the benefit of any warranty given by the component manufacturer to Seller where the third-party manufacturer permits it to do so.

No other warranties.

All other warranties, representations, terms and conditions (express, implied or statutory) as to quality, condition, description, merchantability, fitness for purpose, compliance with sample, or non-infringement (except implied warranty of title) are expressly excluded to the fullest extent permitted by law.

LIMITATION OF LIABILITY

Exclusions. Without limiting the foregoing, Seller will have no liability in respect of:

- (i) failure to follow Seller's use restrictions, specifications, recommendations or instructions or any misuse of the Products; (ii) any alteration, modification, repair, or enhancement of the Products by Buyer or any third party without Seller's prior written consent; (iii) any defect in the Product arising from designs, specifications or materials supplied by Buyer; (iv) any shipping, storage or working conditions different than those advised by Buyer after Seller's delivery of Products to Buyer; (v) chemical attack or wear; (vi) normal wear and tear; (vii) accident; (viii) fraud, negligence or wilful misconduct of Buyer or any of its affiliates or representatives; (ix) any Product for which the purchase price has not been paid in full in accordance with the Agreement.

Limitation.

- (i) In no event will Seller's liability, in the aggregate, for damages arising out of the use of the Product or Services, or arising under this Agreement, whether in contract, tort (including negligence), or otherwise, to Buyer or any other person exceed the amount paid by Buyer to Seller under the Agreement for the Products or Services to which such claim or damages relates; (ii) Seller will not be liable for loss of profit or revenues, loss of use of equipment or systems, loss or deferral of production, interruption of business or loss of contract, loss of use, increased operating costs, or claims of Buyer's customers for any of the foregoing, any special, consequential, incidental, indirect, or punitive damages, whether or not foreseeable at the date of Seller starting performance of the Agreement and even if Seller is advised in advance of the possibility of any such loss or damages.

INDEMNITY

Each party will indemnify the other party from and against claims brought by a third party, on account of personal injury or damage to the third party's tangible property, to the extent caused by the negligence of the indemnifying party in connection with this Agreement. If the injury or damage is caused by joint or concurrent negligence of Buyer and Seller, the loss or expense will be borne by each party in proportion to its degree of negligence. For purposes of Seller's indemnity obligation, no part of a Product is considered third party property, and "third party" does not include Buyer or any subsequent owner of the Products, their subsidiaries, parents, affiliates, agents, successors, or assigns, including any operation or maintenance contractor, or their insurer.

EXCUSED PERFORMANCE/FORCE MAJEURE

A party will not be liable in respect of the non-performance of any of its obligations to the extent such performance is prevented by any circumstances beyond its reasonable control including but not limited to, strikes, lock-outs or labour disputes of any kind (whether relating to its own employees or others), fire, flood, explosion, natural catastrophe, military operations, blockade, sabotage, revolution, riot, civil commotion, war

Ebara HG ULC
5 Brigden Gate · Halton Hills · ON · CANADA · L7G 0A3
T: 905-693-8595
<https://www.ebarahg.com>



EBARA
HAYWARD GORDON

EBARA HG ULC
5 Brigden Gate
Halton Hills, ON L7G 0A3
☎ (905) 693-8595
www.ebarahg.com

or civil war, acts or threats of terrorism. If such an event occurs, the time for performance will be extended by the amount of time lost by reason of the event plus such additional time as may be needed to overcome the effect of the event.

COMPLIANCE WITH LAWS

Each party shall comply with all applicable laws and regulations, orders, ordinances, resolutions, decrees, or restrictive measures and/or other requirements, including, but not limited to, import and export control, anti-bribery and anti-money laundering laws, regulations, codes, or ordinances. In no event shall buyer use, divert, import, export, or re-export products and/or technology in violation of such applicable laws and regulations.

Buyer hereby certifies that it will not export, re-export, or transfer all or part(s) of the products to Iran, North Korea and any countries of the sanctioned countries under the laws and regulations applicable to seller.

GOVERNING LAW

Unless otherwise agreed to in writing, the laws of the jurisdiction from which Seller ships the Product(s) will govern the interpretation and construction of this Agreement, and the Parties agree to submit to the exclusive jurisdiction of the courts of such jurisdiction.

Waiver. No waiver of any of the provisions of this Agreement will constitute a waiver of any other provision (whether or not similar).

Severability. If any provision of this Agreement is determined to be illegal, invalid or unenforceable, that provision will be severed from this Agreement and the remaining provisions will remain in full force and effect.

Assignment/Subcontracting.

Seller may assign or novate its rights and obligations under this Agreement, in whole or in part, to any of its affiliates. Seller may subcontract portions of the work to any third party.